

KP-F120 Series

HITACHI

KP-F120

KP-F120CL

KP-F120USB

KP-F120F

KP-F120C

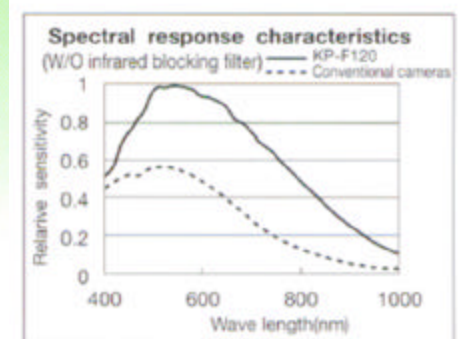

Progressive Scan, High Resolution, 1.45 Million Pixel Digital Output Camera

Features

- Near IR Sensitivity
- Spectral Response Extends above 1000 nm
- 2/3 inch 1.45 Million Pixel CCD
- 1392 (H) x 1040 (V) Pixels
- Frame rates of 15, 30, 60 or 120 F / sec
- Progressive Scan with Square Pixels
- Analog Progressive Scan Output
- Choice of Digital Outputs:
 - Dual Channel 10 bit RS-644 (LVDS) KP-F120
 - Single Channel 8 bit LVDS (KP-F120C)
 - Color Version with Bayer Filter
 - CameraLink KP-F120CL
 - USB2.0 KP-F120USB
 - IEEE-1394 KP-F120F
- Multiple Step Electronic Shutter
- Frame-on-Demand Mode
- Partial Scan Mode
- RS-232C Remote Control
- C-Mount Optics
- Compact Size

Featuring a 2/3 inch 1.45 Million Pixel Progressive Scan CCD, the **KP-F120** combines high resolution and high sensitivity with good spectral response. Useable in the Near IR range, the spectral response extends above 1000 nm. Providing a standard aspect ratio of 4 : 3 the CCD features square pixels. Through the use of advanced IC technology, the camera is able to provide a multitude of features in a compact size. A choice of digital output formats allows the camera to be tailored to the imaging system of the customers choosing. For use in high performance machine vision systems, the camera features a Frame-on-Demand mode that allows an image to be captured and output immediately following the use of a trigger pulse. For even higher frame rates the **KP-F120** features a partial scan mode where the scan can start at the top or the center of the frame and continue for the chosen number of lines (16H to 512H). For ease of use, the **KP-F120** has an RS-232C remote control port that allows remote control of all camera operating functions. The camera is available as the **KP-F120** with a dual channel RS-644 (LVDS), with a CameraLink output, as the **KP-F120CL**, with a USB2.0 output, as the **KP-F120USB**, with a IEEE-1394 output, as the **KP-F120F**, or as a color version with a single channel 8 bit LVDS output as the **KP-F120C**.

Specifications

Imager	2/3 inch interline CCD
Effective Pixels	1392(H) x 1040(V)
Pixel Pitch	6.45µm(H) x 6.45µm(V)
Imaging Area	8.98mm(H) x 6.71mm(V)
Scanning System	Progressive
Sensitivity	400 lux f4.0 3200 k
Aspect Ratio	4 : 3
S/N	54db
Frame Rate	30F/s (full) to 120F/s (partial scan) LVDS / Camera Link, 15F/s (full) to 120F/s (partial scan) USB2.0 / IEEE-1394. 15F/s (full) to 60 F/s (partial scan) KP-F120C.
H. Scan Freq.	32.07KHz
Synchronization	Int. / Ext. Auto Switch
Lens Mount	C-Mount
Flange Focal Distance	17.526mm
Video Output	Digital output or analog for image checking.
Digital Outputs	EIA-644 (LVDS dual channel 10 bits 28.8 MHz EIA-644 (LVDS single channel 8 bits KP-F120C Camera-Link USB2.0 (approx. 15 f/s) IEEE-1394 (approx. 15 f/s)
External Sync Input	HD/VD TTL level negative input impedance: 10K Ω , Freq. \pm 0.0005%
Electronic Shutter	External Switch Selection 1/30, 1/60, 1/125, 1/250, 1/1000, 1/2000, 1/10000, 1/50000 second
Frame-on-Demand	Fixed Shutter, One Trigger, Two Trigger Modes
Partial Scan Mode	Upper or Middle 16H, 32H, 64H, 128H, 256H, 512H
Trigger Polarity	Selectable: positive / negative
Accelerated Mode	2 times @ 60 f/s, 4 times @ 120 f/s 2 times @ 30 f/s, 4 times @ 60 f/s KP-F120C
Gain Select	0 to 15 db in 1 db steps
Remote Control	KP-F120 RS-232C using remote connector KP-F120CL provided via Camera-Link KP-F120USB provided via USB
Power Requirements	12 \pm 1 VDC @ 400 ma.
Size (W x H X D)	58 x 58 x 48 mm
Weight	220 Grams
Ambient, Operating	0 to 40°C (+32 to 104F) less than 90% RH

Dimensions

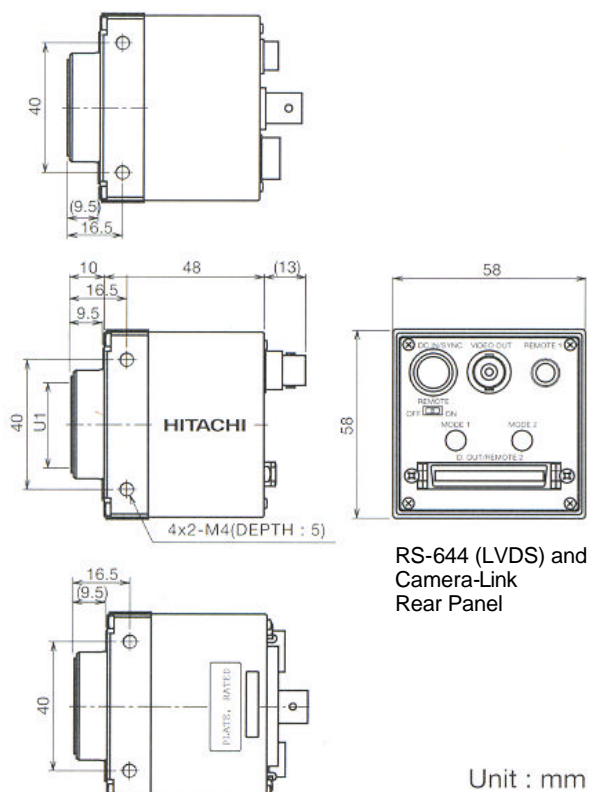

RS-644 (LVDS) and Camera-Link Rear Panel

Standard Composition

- (1) Camera (with infrared blocking filter)
- (2) Operating Instructions
- (3) KP-120USB includes USB Driver and Demo Software
- (4) KP-120F includes IEEE-1394 Driver and Demo Software

KP-F120USB

USB2.0 Rear Panel KP-F120USB includes USB2.0 driver and demo software.



Requirement: Pentium 4, 1.4 GHz or higher (Pentium 4, 2.0 GHz or higher is recommended).

Video adapter: 24 or 32 bits, color, 1024 x 768 min.

Memory: 256 MB, (512 MB or more recommended).

USB2.0 Host: NEC $\dot{\iota}$ PD720100A

System: Microsoft Windows 2000 (SP2 or later),
Microsoft Windows XP (SP1 or later)

KP-F120USB SDK: A software development kit is available for those wishing to write custom software.

KP-F120F

KP-F120F includes IEEE-1394 driver and demo software.

Requirement: Intel Celeron 533 MHz or more.

Memory: 256 MB or more.

System: Microsoft Windows 98SE, ME, 2000, XP.

Interface: OHCI IEEE-1394 Interface PCI Board.
OHCI IEEE-1394 Interface PC Card.

Display Adapter: 24 bit RGB color or more.

KP-120F SDK: A software development kit is available for those wishing to write custom software.

IEEE-1394 Rear Panel



Frame-on-Demand Operation

With the frame-on-demand function, moving objects can be captured at an optimal exposure and timing by the use of an external trigger pulse.

Fixed Shutter Mode

When one trigger pulse (TRIG A) is supplied, the exposure starts at the rising edge of input pulse. Exposure time is fixed, and set by the electrical shutter speed switches on the camera. V-SYNC is reset, and the picture is delivered immediately.

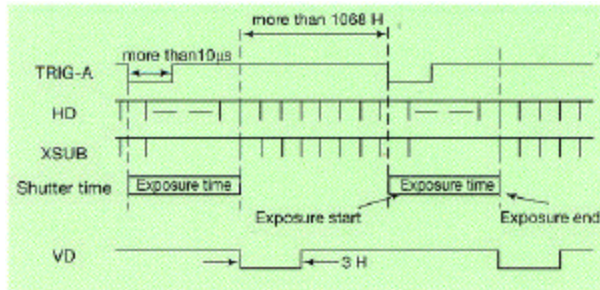

Two Trigger Mode

When two trigger pulses (TRIG A and TRIG B) are supplied, exposure starts at the rising edge of the TRIG A pulse, and ends at the falling edge of the TRIG B pulse. The period between the two pulses is the exposure time. V-SYNC is reset and the picture is delivered immediately.

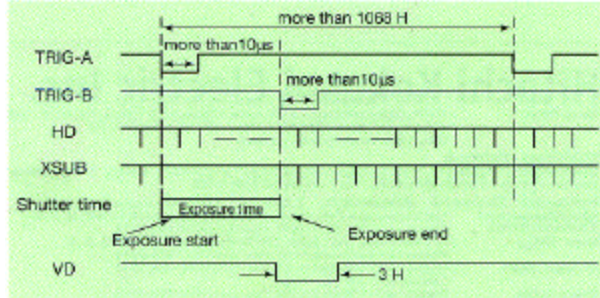

One Trigger Mode

When one trigger pulse (Trig A) is applied, exposure starts at the rising edge of the input pulse, and ends at the falling edge of the pulse. The pulse width is the exposure time. V-SYNC is reset and the picture is delivered immediately.

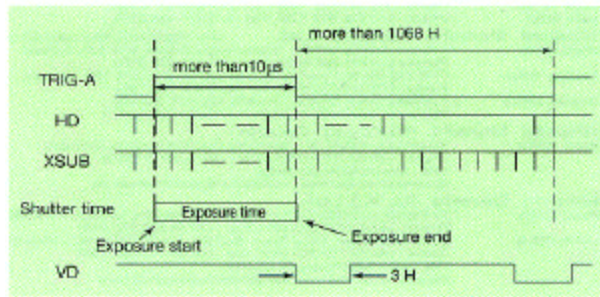

KP-F120C Bayer Filter Structure

The KP-F120C outputs raw Bayer Filter Color Data that is combined in the frame grabber to produce a color image. Below is a partial diagram showing the output structure of the CCD with the Bayer Filter.

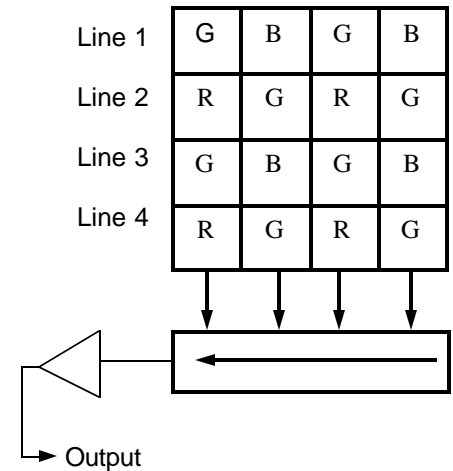

KP-F120 / KP-F120CL Rear Panel Switches

The camera rear panel includes switches for electronic shutter data, readout rate, gain control, and frame-on-demand on/off and mode switches.

REMOTE ON/OFF switch



MODE ON/OFF switch

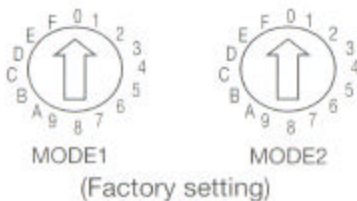

MODE 1, MODE 2 Position Select

SW POS.	MODE 1	MODE 2	SW POS.	MODE 2		
				(1)	(2)	(3)
0	Normal Mode	(1)	0	0 db	1/30	16H
1	One Trigger Mode		1	1 db	1/60	32H
2	Two Trigger Mode		2	2 db	1/125	64H
3	Quad Speed Mode		3	3 db	1/250	128H
4	Quad Speed Mode + One Trigger Mode		4	4 db	1/1000	256H
5	Smear Reduction Mode + One Trigger Mode		5	5 db	1/2000	512H
6	Smear Reduction Mode + Two Trigger Mode		6	6 db	1/10,000	512H
7	Smear Reduction Mode Quad Speed Mode + One Trigger Mode	7	7 db	1/50,000	512H	
8	Normal Shutter Mode	(2)	8	8 db	1/50,000	512H
9	Fixed Shutter Mode		9	9 db	1/50,000	512H
A	Smear Reduction Mode + Fixed shutter Mode		A	10 db	1/50,000	512H
B	Partial Scan (Normal Mode) Read Pos. Center	(3)	B	11 db	1/50,000	512H
C	Partial Scan (Normal Mode) Read Pos. Upper		C	12 db	1/50,000	512H
D	Partial Scan (One Trigger Mode) Read Pos. Center		D	13 db	1/50,000	512H
E	Partial Scan (One Trigger Mode) Read Pos. Upper		E	14 db	1/50,000	512H
F	Twice Speed Mode		F	15 db	1/50,000	512H

KP-F120 / KP-F120CL
Connections to DC IN and SYNC (12 pin)

KP-F120CL Camera-Link Digital Output Connector 10226-5202JL (3M)

Pin No.	Internal Sync	External HD / VD	External Sync		
			Frame-on-Demand		
			Fixed Shutter	Two Trigger	One Trigger
1	GND	GND	GND	GND	GND
2	+12 V	+12 V	+12 V	+12 V	+12 V
3	GND	GND	GND	GND	GND
4	VIDEO	VIDEO	VIDEO	VIDEO	VIDEO
5	-	Ext HD GND	GND	GND	GND
6	-	Ext HD Signal	-	-	-
7	-	Ext VD Signal	Trig -A Signal	Trig -A Signal	Trig -A Signal
8	GND	GND	GND	Trig-BGND	GND
9	-	-	WEN	Trig-B Signal	WEN
10	GND	GND	GND	GND	GND
11	+12 V	+12 V	+12 V	+12 V	+12 V
12	GND	Ext VD GND	Trig-A GND	Trig-A GND	Trig-A GND

Pin No.	Signal Name	Pin No.	Signal Name
1	GND	14	GND
2	TXOUT 0 (-)	15	TXOUT 0 (+)
3	TXOUT 1 (-)	16	TXOUT 1 (+)
4	TXOUT 2 (-)	17	TXOUT 2 (+)
5	TXCLKOUT (-)	18	TXCLKOUT (+)
6	TXOUT 3(-)	19	TXOUT 3(+)
7	RX (+)	20	RX (-)
8	TX (-)	21	TX (+)
9	TRIG-AVD(-) {CC1 (-)}	22	TRIG-AVD(+) {CC1 (+)}
10	TRIG-B (+) {CC2 (+)}	23	TRIG-B (-) {CC2 (-)}
11	EXT-HD (-) {CC3(-)}	24	EXT-HD (+) {CC3(+)}
12	NC {CC4(+)}	25	NC {CC4(-)}
13	GND	26	GND

External input signals are not connected in the **KP-F120CL**

KP-F120 and KP-F120C (Bold Designations Only)
Digital Output Connector EIA-644 (50 pins) DX10G1M-50S

Pin No.	Signal Name	Pin No.	Signal Name	Pin No.	Signal Name	Pin No.	Signal Name
1	DATA DB-D0 (+)	2	DATA DB -D0 (-)	26	DATA DA-D0 (+)	27	DATA DA -D0 (-)
3	DATA DB-D1 (+)	4	DATA DB -D1 (-)	28	DATA DA-D1 (+)	29	DATA DA -D1 (-)
5	DATA DB-D2 (+)	6	DATA DB -D2 (-)	30	DATA DA-D2 (+)	31	DATA DA -D2 (-)
7	DATA DB-D3 (+)	8	DATA DB -D3 (-)	32	DATA DA-D3 (+)	33	DATA DA -D3 (-)
9	DATA DB-D4 (+)	10	DATA DB -D4 (-)	34	DATA DA-D4 (+)	35	DATA DA -D4 (-)
11	DATA DB-D5 (+)	12	DATA DB -D5 (-)	36	DATA DA-D5 (+)	37	DATA DA -D5 (-)
13	DATA DB-D6 (+)	14	DATA DB -D6 (-)	38	DATA DA-D6 (+)	39	DATA DA -D6 (-)
15	DATA DB-D7 (+)	16	DATA DB -D7 (-)	40	DATA DA-D7 (+)	41	DATA DA -D7 (-)
17	DATA DB-D8 (+)	18	DATA DB -D8 (-)	42	DATA DA-D8 (+)	43	DATA DA-D8 (-)
19	DATA DB-D9 (+)	20	DATA DB -D9 (-)	44	DATA DA-D9 (+)	45	DATA DA-D9 (-)
21	TX2	22	RX2	46	CLK OUT (+)	47	CLK OUT (-)
23	GND	24	GND	48	VD OUT (+)	49	VD OUT (-)
25	HD OUT (+)			50	HD OUT (-)	SHIELD	GND

NOTE: Signals shown on the above chart in bold lettering are used in the KP-F120C. The other signal lines are not used in the KP-F120C.

KP-F120 / KP-F120C
(only RS-232 Remote Control Pin Assignment)

Pin No.	Signal Name
1	-
2	RD
3	TD
4	Manual / Remote
5	Ground
6	-

Optional Accessories

- Junction Box
JU-M1A (23831AX)
JU-F1 (23832AX)
- Camera cable (Molded type)
2 m C-201KSM
5 m C-501KSM
10 m C-102KSM
- AC adapter
45601-C4
- Tripod adapter
TA-F120
- Dummy glass (AR coated) ARC1214 (XMD0009)
- 6 pin Remote Plug
HR10A-7P-6P
- 12 pin Plug
HR10A-10P-12S(01) (23810AX)
- D. Out Connector (50 pins) EIA-644
DX30AM-50P (HIROSE)
Camera-Link (26 Pins 10126-5202JL(3M))

Hitachi Denshi America Ltd.

Head Office 150 Crossways Park Drive, Woodbury, NY 11797
Phone: 516-682-4404 Fax: 516-496-3718

Midwest Phone: 330-334-4115 Fax: 330-334-0574

Los Angeles Office 371 Van Ness Way Suite 120 Torrance, CA 90501
Phone: 310-328-6116 Fax: 310-328-6552

Canada Office 1 Select Ave. Unit 14 Scarborough, Ontario M1V 5J3
Phone: 416-299-5900 Fax 416-299-0450