

Preliminary

Compact Progressive Scan Monochrome CCD camera

KP-F30/F33

60 frame per second

30 frame per second



KP-F30/F33

60 frame per second

30 frame per second

We will meet requirement as external trigger and video output etc High Sensitivity and High resolution are provided in compact body Rear panel switches are selected easily.

Frame shutter function

With the frame shutter function, higher resolution in the vertical direction is ensured for moving objects, compared with the conventional shutter function.

- 1/3-inch 330k IT-CCD
High resolution is provided by the Effective pixels 659(H)×494(V) in a square lattice
- Full pixel independent readout
KP-F30 outputs at 60 frames per second
KP-F33 outputs at 30 frames per second

Multi-step electronic shutter function

Eight shutter speeds can be selected from 1/250 to 1/50000 seconds. (KP-F33 : 1/125 to 1/25000seconds.)

External Sync

The sync mode and the scanning mode are automatically switched according to the supplied sync signal.

● Input waveforms

- Horizontal drive signal (HD)

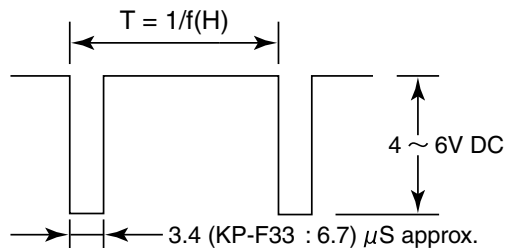

- Vertical drive signal (VD)

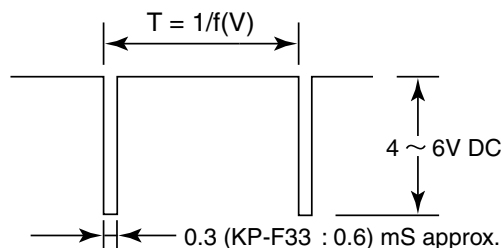

- Phase relationship between horizontal drive signal (HD) and vertical drive signal (VD)

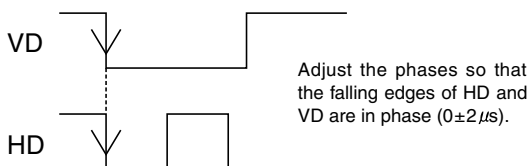

Frame · On · Demand function

With the Frame · On · Demand function, moving objects can be captured at an optional timing. Capture time can be adjusted by the external trigger signal and the shutter function. At 1 trigger input, 1 image output is produced.

● ONE trigger trigger

When one trigger pulse (TRIG) is supplied, exposure starts at the rising edge of the input pulse, and ends at the falling edge of the pulse. Then, the V-SYNC pulse is reset and pictures are delivered immediately. Pulse width is exposure time.

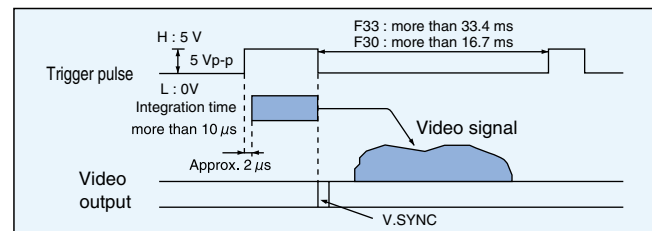

● Fixed shutter trigger

When one trigger pulse (TRIG) is supplied, exposure starts at the rising edge of the input pulse. Exposure time is fixed, and set by the electronic shutter switches on the camera. Video signals are delivered immediately after exposure time ends.

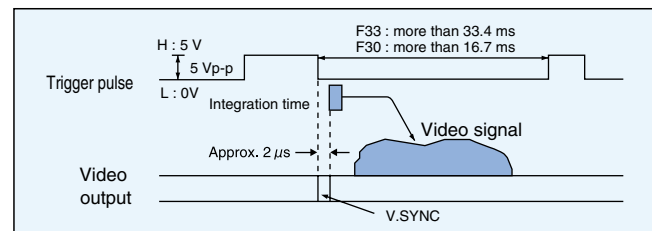

● Reset control trigger

Two Trigger pulses control the output of the image. The pulse width of the first Trigger (TRIGB) controls the exposure. and another one Trigger pulse controls the output timing of the image.

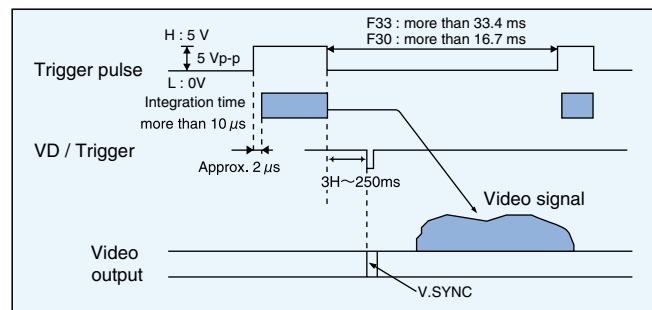

KP-F30/F33 System

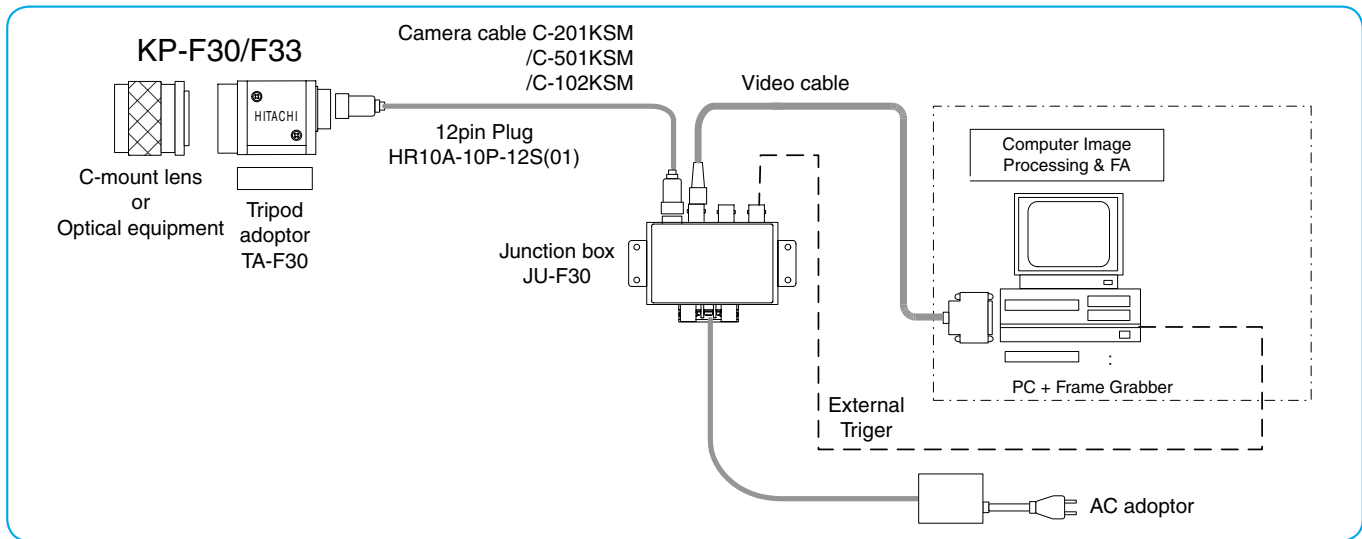

Composition

- (1).....Camera (W/IR cut filter)
 (2).....Operation manual

Optional accessories

- (1) Tripod adaptor.....TA-F30
 (2) 12 pin plug.....HR10A-10P-12S(01)
 (3) Junction box.....JU-F30
 (4) Dummy glass.....ARC1214 (AR coat)
 (5) Camera cable (Molded type)
 2m C-201KSM
 5m C-501KSM
 10m C-102KSM

Optical System

- Image size : 1/3-inch
- The flange focal distance is 17.526mm (in air).
- Flange focal distance cannot be adjusted.

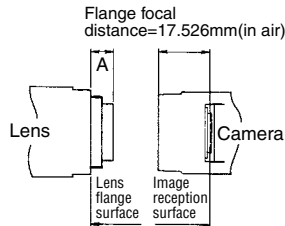

Note
 Select such a lens as the length (A) from the lense surface of the lens to the end of the screw side is 8mm or less.

Optional Accessories

Tripod Adaptor, TA-F30

Use the tripod adaptor when fixing a camera with the screws for a tripod. Fix the tripod adaptor to the camera with the supplied screws (M3x6, 4pcs).

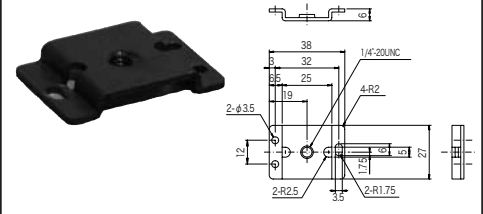

12-pin Plug

HA10A-10P-12S(01)



Junction Box, JU-F30

Connect to a camera, using a camera cable.

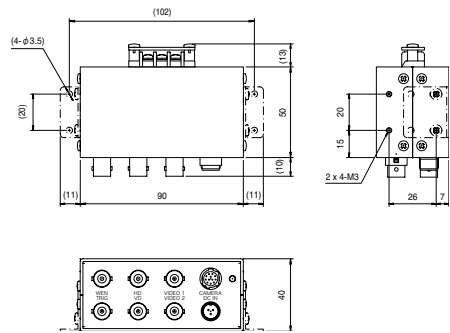

Camera Cable

Molded type
 2m C-201KSM
 5m C-501KSM
 10m C-102KSM



Hitachi Kokusai Electric Inc.

Head Office : 1-4-20, Higashi-Nakano 3-choume, Nakano-ku, Tokyo 164-8511, Japan
 Phone : +81 (0) 3-3368-6111, Fax : +81 (0) 3-3365-9119
 URL: <http://www.h-kokusai.com>

Beijing Office
 Beijing Fortune Building 5, Dong San Huan Bei-Ju, Chao Yang District, Beijing, 100029 China
 Phone : +86 (0) 10-6590-8755/8756, Fax : +86 (0) 10-6590-8757

Hitachi Denshi America, Ltd. URL: <http://www.hdal.com>
 Headquarters and Northeast Office : 150 Crossways Park Drive, Woodbury, New York 11797, U. S. A.
 Phone : (+1) 516-921-7200, Fax : (+1) 516-496-3718

West Office : 371 Van Ness Way, Suite 120 Torrance, CA, 90501, U. S. A.
 Phone : (+1) 310-328-6116, Fax : (+1) 310-328-6252

Midwest Sales : Phone : (+1) 300-334-1115, Fax : (+1) 516-496-3718
 Service (+1) 989-345-5379

South Sales : Phone : (+1) 770-982-4724, Fax : (+1) 516-496-3718
 Service (+1) 256-774-3777

Parts Center Latin Sales : Phone : (+1) 516-682-4435, Fax : (+1) 516-921-0993
 Phone : (+1) 516-682-4420, Fax : (+1) 516-496-3718

Hitachi Denshi Canada, Ltd. URL: <http://www.hitachidenshi.ca>
 Head Office : 1 Select Avenue Unit#11 Scarborough, Ontario M1V 5J3, Canada.
 Phone : (+1) 416-299-6300, Fax : (+1) 416-299-0450

Eastern Office : 5795 Chemin St. Francois St. Laurent, Quebec H4S 1B6, Canada
 Phone : (+1) 514-332-6687, Fax : (+1) 514-335-1664

Hitachi Denshi (Europa) GmbH
 Head Office : Weskircher Straße 88, Jügesheim D-63110 Rodgau, Germany
 Phone : +49 (0) 6106-69920, Fax : +49 (0) 6106-16906
 URL : www.hitachi-denshi.de
 General email address : webmaster@hitachi-denshi.de

Hitachi Denshi (U. K.) Ltd.
 Head Office : 14 Garrick Industrial Centre, Irving Way, Hendon, London, NW9 6AQ, United Kingdom
 Phone : +44 (0) 208-202-4311, Fax : +44 (0) 208-202-2451
 URL : www.hitachi-denshi-uk.com
 Leeds Office : Brookfield House, Selby Road, Garforth, Leeds LS25 1NB United Kingdom
 Phone : +44 (0) 113-287-4400, Fax : +44 (0) 113-287-4260
 URL : www.hitachi-denshi-uk.com
 General email address : sales@hitachi-denshi-uk.com

These products are manufactured at a factory which has received quality control system certification in accordance with the ISO international standards.



CERTIFICATE NO. JMI-0082
 ISO 9001/BS 5750P11
 EN 29001/JIS 29001